

Technical Information

Elevate - Refrigerated Autonomous Retail Merchandiser

Structural Concepts®

DELIVERING FRESH. ALWAYS.™

| DIMENSIONS / SHIPPING | | | | |
|-----------------------|-----|--------|-------|--------------|
| Model | L" | L1" | L2" | Est Wt (lbs) |
| BD3632IS | N/A | 45.375 | 0.000 | 1,300 |

| ELECTRICAL | | | | | | | | | | | | | | | |
|------------|-----------------------|------------|---------|----|-----|-----------------|--------------|--------------|-------|-------|-----------------|-------------|-----------|------------------|-----------------------|
| Model | System Circuit Volts | | | Ph | Frq | Rated Load Amps | Min Cir Amps | Max OCP Amps | Watts | Wires | NEMA Plug | Amps Lights | Amps Fans | Amps Anti-Sweats | Amps Misc/Refrig/Heat |
| BD3632IS | Self-Contained (R290) | Circuit #1 | 110-120 | 1 | 60 | 11.51 | 15 | 15 | 477 | 2+G | 5-15P or L5-15P | N/A | 0.31 | N/A | 11.20 |

| REFRIGERATION | | | | | | | | | | | | | | |
|---------------|------|---------|---------------------|---------|----------------------|-----------------|-----------------|------------------------|------------------|-----------------------------|---------------------|-------------|------------------|-----|
| Model | Zone | Section | System | Envt | REMOTE REFRIGERATION | | | | | GLYCOL / R744 REFRIGERATION | | | | |
| | | | | | SST (°F) | Conv. Rack BTUH | Para. Rack BTUH | Defrost Interval (Hrs) | Defrost Duration | Total GPM | Pressure Drop (psi) | Concent (%) | Liquid Temp (°F) | |
| BD3632IS | All | Main | Self-Contained-R290 | Type II | N/A | N/A | N/A | N/A | N/A | N/A | N/A | N/A | N/A | N/A |

| INTENDED ENVIRONMENT | | |
|--|-----------|---|
| Type II - Designed to operate in ambient conditions of 80°F and 55% relative humidity unless noted otherwise under Envt above. | | |
| WARMEST AVERAGE PRODUCT TEMP & INTENDED USE OF ZONES | | |
| Zone | Temp (°F) | Intended Use |
| 1 | 40 | Packaged refrigerated products-Prechilled to Warmest Avg Prod Temp. |

| IMPORTANT NOTES |
|--|
| 1) ARM Form required at time of PO for this standalone unit w/ E-Box. |
| 2) Performance issues (product temperatures, water on floor, etc.) caused by adverse conditions are not covered by warranty. |
| 3) Keep unit at least 15' from exterior doors, overhead HVAC vents, or any air curtain disruption. |
| 4) End panels must be tightly joined or kept at least 6" away from any structure to prevent condensation. |
| 5) Do not expose unit to direct sunlight or any heat source (ovens, fryers, etc.). |
| 6) Tile floors, low ceilings, or small rooms will increase noise level. |

| REGULATORY | |
|------------|---|
| All Models | ETL Listed to UL 541 ETL Listed to CAN/CSA 22.2 No. 128 ETL Sanitation to NSF/ANSI 25 |



Technical Information

Elevate - Refrigerated Autonomous Retail Merchandiser

Structural Concepts®

DELIVERING FRESH. ALWAYS.™

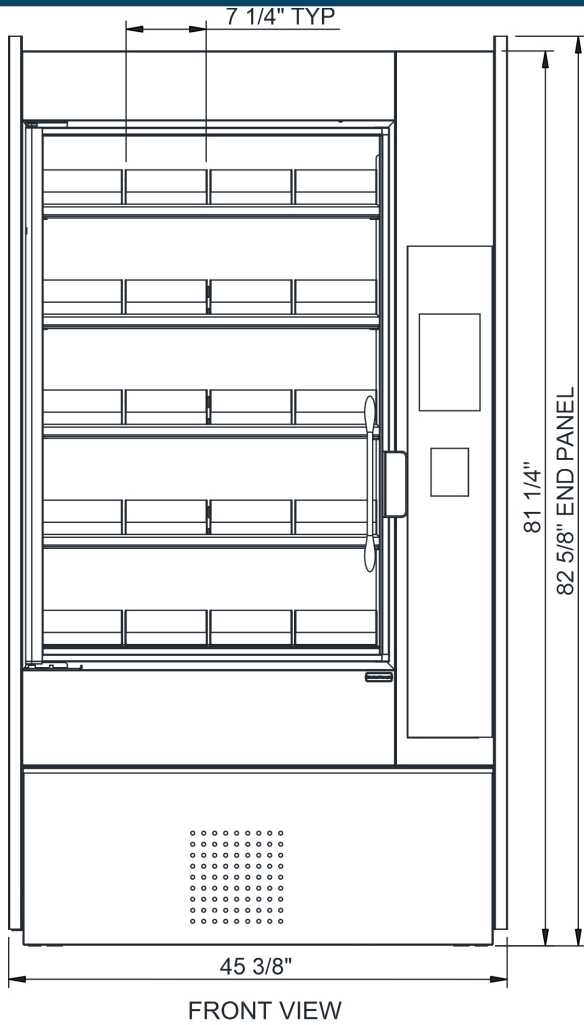

FRONT VIEW

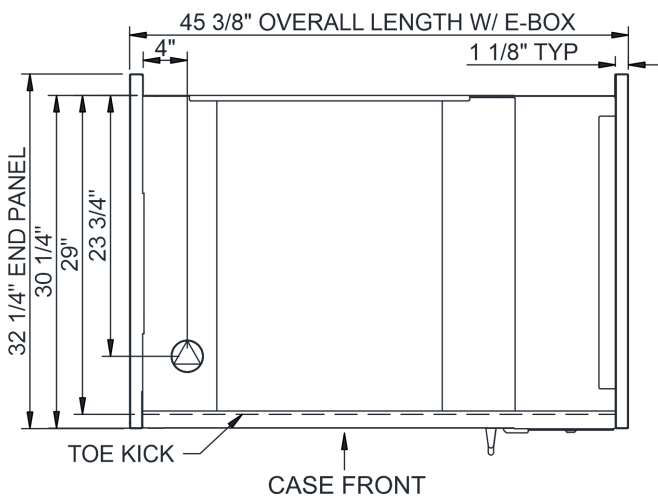
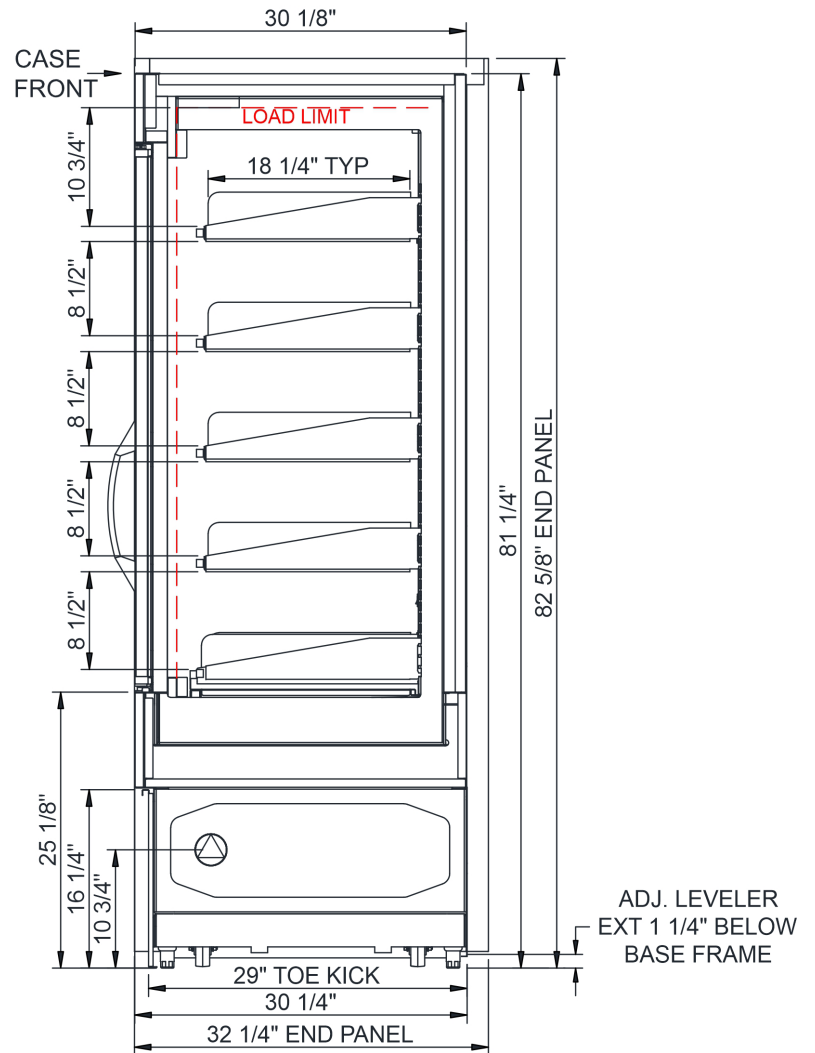

NOTES:

1. SHELF TRAY DIMENSIONS: 7 1/4" W X 18 1/4" D
2. BD3632IS SELF-CONTAINED ACCESS ONLY BY PULLING OUT CONDENSER DRAWER.
3. COMPRESSOR AIR FRONT INTAKE AND LOWER REAR DISCHARGE. LOWER FRONT PANEL CANNOT BE BLOCKED.

NOTE: ALL DIMENSIONS APPROXIMATE

⊗ ELECTRICAL JUNCTION BOX (SUPPLIED WITH 6" LEADS OR POWER CORD).
 ⊙ LOCATION OF DRAIN TUBE FOR REMOTE REF. ONLY (SUPPLIED WITH 3/4" OR 1 1/2" PVC TUBE).

⊕ REFRIGERATION LINE CONNECTION.
 ☒ REMOTE FLOOR SINK & UTILITIES ACCESS AREA.

⊞ SELF-CONTAINED CASE SERVICE ACCESS AREA.
 ⊞ DRY CASE SERVICE ACCESS AREA.